

Copyboard Catalog

PLUS



PLUS Stationery Company
Meeting Products Division

Tel +81-(0)42-370-8216 Fax +81-(0)42-370-8226 E-mail plusvision@plus.co.jp
Inagi Office 1033-1, Oshitate, Inagi-shi, Tokyo 206-0811, JAPAN

For more information ► <http://www.plus-vision.com/en>

Specifications are subject to change without notice. Printed in Japan V-020 1202R

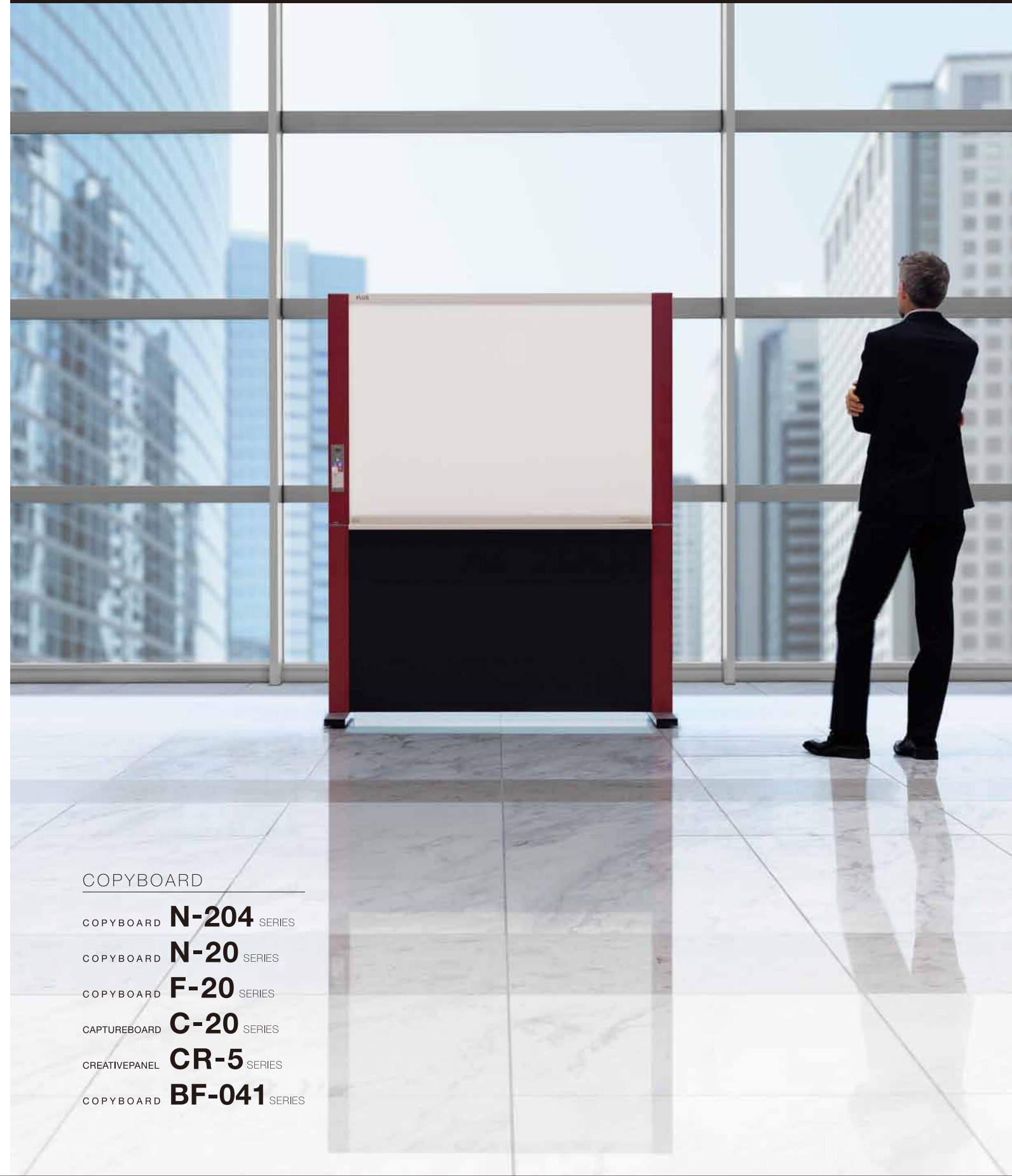

COPYBOARD

COPYBOARD **N-204** SERIES

COPYBOARD **N-20** SERIES

COPYBOARD **F-20** SERIES

CAPTUREBOARD **C-20** SERIES

CREATIVEPANEL **CR-5** SERIES

COPYBOARD **BF-041** SERIES

SIMPLE OPERATION

Record your ideas without pausing your train of thought.

Meetings are a meeting of minds – a place where everybody puts their heads together and great ideas are born. You don't want a complicated machine that will stop the flow of ideas. You want an easy-to-use tool that will work as quickly as your mind does. Enter the new series of Copyboards from PLUS. PLUS is the company that first brought you the Copyboard, and PLUS has been working constantly since then, developing ever better products for you. Here are the latest and greatest in creative meeting tools.



Network Function

No need for notepads or USB memory sticks!
Just write your ideas on the Copyboard and share them over a network.



The board is accessible via a web browser

Scan and save up to 100 pages to the Copyboard's internal web server. No need to export data to a computer or memory stick. Just plug in a LAN cable and you'll be able to share your meeting minutes. You can even choose from a variety of network settings to password-protect sensitive information.

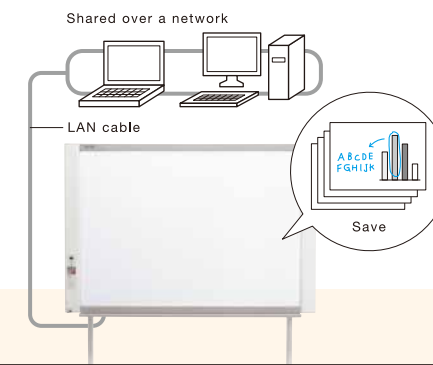

No note taking enables you to have a productive meeting

The best ideas come when everyone can concentrate on the discussion, without being distracted by taking notes. Now everyone can view the meeting notes at anytime over the network. No more getting out a memo pad or USB memory stick—everyone is free to give the meeting their full attention.



Secure your information

Worried about papers or USB memory sticks falling into the wrong hands? By viewing your meeting minutes over the network, you can protect sensitive information and make sure that it is only seen by the appropriate individuals.



Slim and light

Don't bring your meeting to the Copyboard, bring your Copyboard to the meeting. This new Copyboard is easy to move to the location of your choice.



Sliding sheet

When you run out of space, just slide the sheet with your hand and make more room. Carry on your writing without interrupting the flow of ideas.



40% thinner than previous boards

The PLUS N-20 Copyboard's slim design (only 72mm/2.8" thick) makes it easier to move around compared to other bulky boards.

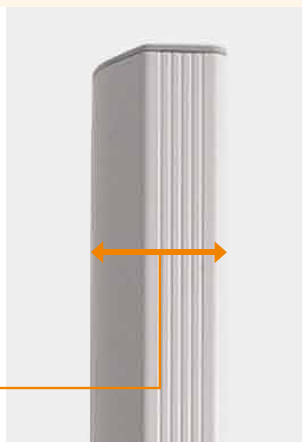

Light enough for anybody to move

The board is also 22% lighter than previous boards, making it easy to move.



Easier to scroll... and you can scroll in either direction

You can scroll the sheet forward or backward with the touch of a hand. No more pausing your train of thought when you run out of space or need to see what you've written on the other side of the sheet.



Discussion + writing = synergy

Writing is an invaluable element of dynamic discussions. Visual brainstorming allows you to organize your ideas, make connections and reinforces memories. The best discussions happen when everyone is giving their full attention, and with this new Copyboard everyone can do just that. And now you can be confident in the knowledge that everything you write is being saved for easy reference later.

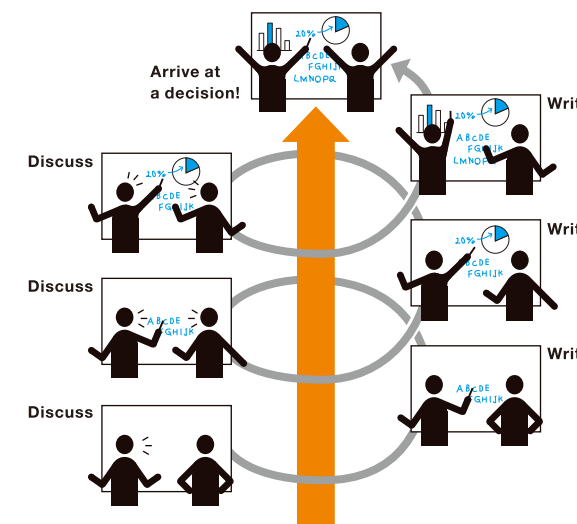

Make every stage of your meeting stress-free

From pre-meeting preparations to post-meeting follow-ups, PLUS Copyboards make it easy. The boards have a wealth of functions that improve the speed and quality of your meetings at every step along the way.

Setup

○ Anywhere you choose !

The board is 40% thinner than previous models, and the legs have been designed to take up minimal space.



○ Easy to move

20% lighter than previous models, making it easy for anybody to move.

Other Features

○ No special software

The board is accessible via a web browser and all board settings (file format, date settings, resolution etc.) and security settings can be configured in a browser on your computer. You don't need to install special software. The board is compatible with all operating systems.

*The settings can also be changed using the board's control panel.

○ Save energy

Previous boards have used 40W during operation and 5W during stand-by. The new series from PLUS uses only 12W during operation and 3W during stand-by. You won't find a more energy-efficient board than this!

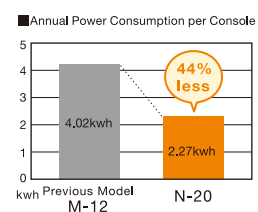

*Measurement conditions: Used at three one-hour meetings per day. Two screens were scanned at each meeting. The standard "S" model was used.

Write

○ Smooth-sliding sheet for uninterrupted discussions

Slide the sheet with your hand to make more room to write without interrupting your discussions.

○ Magnet-attachable surface

Use magnets to stick drawings and the like onto the board. (This is the first sheet-type Copyboard with this function.)



○ Attach other items

Need a timer or calculator? Stick it to the frame of the board! You can stick a magnetic sheet (optional) to the frame side, thereby customizing the board to suit your needs. (This is the first sheet-type Copyboard with this function.)



Scan

○ One-touch operation

Simple—designed control panel allows you to operate it intuitively.



○ Quieter

The scan noise has been reduced from 50dB to 43dB. No more noisy scanning disrupting your discussion or train of thought.

*As a point of reference, a quiet office is 50dB and the average library is 40dB.

○ Faster scan time

Color scanning now takes only 15 seconds—35% faster than previous models.

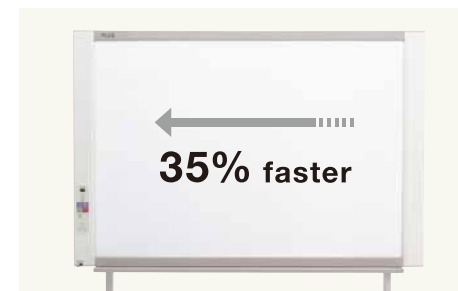

○ Erase reminder function

You can set the Copyboard to scroll through the sheet when you turn it off—no more forgetting to erase.

*This feature is set to "off" as the factory default.

Save

○ Network function—no hard drive necessary !

The board is accessible via a web browser—no need for a USB memory stick or a direct PC connection to save the information. You can now simply view your information over a network.

○ Save directly to your computer

With a USB cable connection, save your information straight to your computer. No special software is needed, the board is compatible with all operating systems, and only one page of data is saved for added security. When you remove the USB cable, your data will be automatically erased from the board's memory.

○ Front-facing USB port

The USB port is front-facing making it easy to insert your USB memory stick. At a glance you can see which way to insert the USB memory stick. A 1GB memory stick will hold around 4800 pages.



○ 3 file formats

Save in PNG, JPEG or PDF formats. View the file on your computer, attach it to an email or paste it into a document.



○ Security functions

Configure the security settings in the browser. You can disable the ability to save to a USB drive as well as disable the transferring of image files to a computer.

Print

○ Detailed print format settings

The browser enables easy configuration of settings such as paper size and date and even allows you to add a header or footer.

*This can also be done using the control panel if the board is not connected to a network.



○ Disable color printing

You can disable color printing mode if black and white only is preferred.

COPYBOARD
N-204
SERIES

4-Panel Type

The board has a sheet size equivalent to 4 writing panels—enough space to hold all of the ideas generated during an active meeting. No need to stop and erase; Just keep on writing!



4 panels of writing space

As shown in the illustration, the sheet is stored in a loop formation, with 4 panels of writing space! Move the sheet forward or backward with a touch of your hand—you won't run out of space!

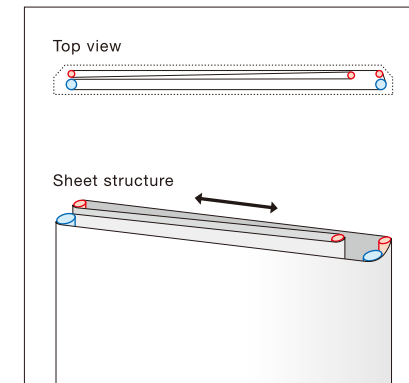

Plenty of space for long meetings

Long meetings result in a lot of information, and PLUS has made it easier to record it all. No more stopping to save and erase—keep everything and go back to what you wrote earlier with a single touch. You can even shrink your 4 writing panels of information to a thumbnail image and print it all on one page.

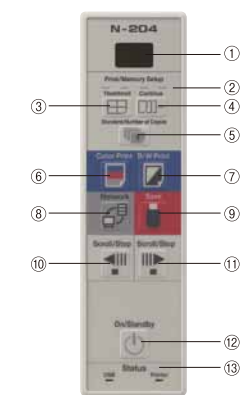
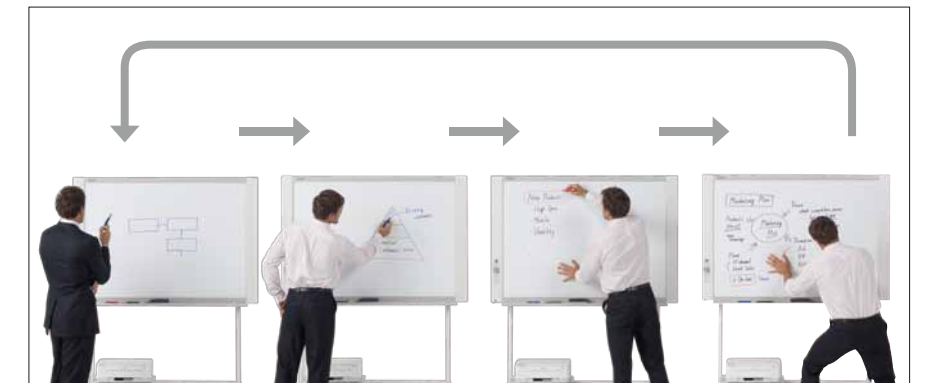

A simpler control panel

The simple-designed control panel allows you to operate the board intuitively.

- ① Display Window
- ② Consecutive printing number indicators
- ③ Thumbnails button
- ④ Consecutive button
- ⑤ Number of Copies
- ⑥ Color Print button
- ⑦ Monochrome Print button
- ⑧ Network button
- ⑨ Save to USB memory stick button
- ⑩ Scroll/Stop button (Left)
- ⑪ Scroll/Stop button (Right)
- ⑫ Power button
- ⑬ Status /Error notification

Configure settings in the browser

Copyboards used to require special software. Not anymore! With this Copyboard you can configure your settings in the browser, no matter what operating system you have. *Setup required for board network

- [Setup Items]**
- Saving file format
 - Security configuration (Disable to save to USB memory stick or computer)
 - Date setting
 - Resolution, Aspect ratio, etc

N-204 SERIES

• N-204 with optional stand



• N-204 with optional stand and printer



[Main Features]

- Width of the board : 1300mm/52"
- Number of Panels : 4 panels
- Hand-scrollable sheet
- Network function
- Color/Monochrome print (when connecting with a printer)
- Save to USB memory stick
- Save to computer (No software is required)
- Security (Disable to save to USB memory stick or Network, Disable to save computer Erase Reminder function)
- Color Mode Restriction
- Low Power Consumption
- Quiet operation
- Magnet attachable panel
- Stand height adjustment
- Thumbnail / Consecutive Print

The sheet maintenance
In order to keep quality of the sheet, please wipe the sheet with a water-damp cloth regularly.

COPYBOARD
N-20
SERIES

Standard Model

The stanard model of the new PLUS Copyboard has two writing panels, network functionality and possesses a clean design that compliments any office space.



Easy to move

This new Copyboard is the lightest model in the industry, making it easy for anybody to move it to a meeting location. (Applies to all of the new series models except N-204 and F-20.)



40% slimmer

This new Copyboard is only 72mm /2.8" – 42% slimmer than previous models (125mm/5"). (Applies to all of the new series models except N-204 and F-20.)

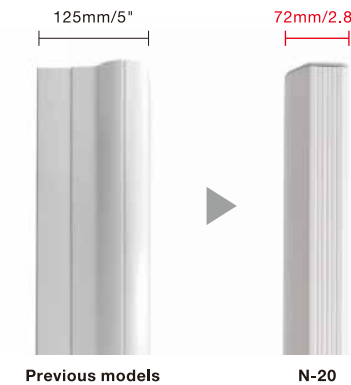

Two board sizes

Choose the Wide model if you want extra room or the Standard model if you'd like something more compact. With two sizes, there's something to suit everybody's office or meeting style. (Both the N-20 and C-20 series.)

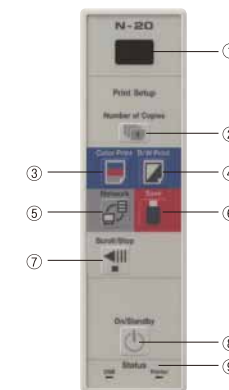
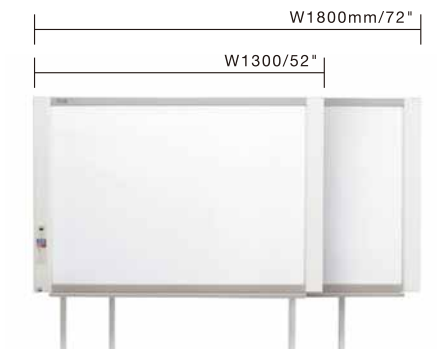

A simpler control panel

The simple-designed control panel allows you to operate the board intuitively.

- ① Display Window
- ② Number of Copies
- ③ Color Print button
- ④ Monochrome Print button
- ⑤ Network button
- ⑥ Save to USB memory stick button
- ⑦ Scroll/Stop button
- ⑧ Power button
- ⑨ Status /Error notification

Configure settings in the browser

Copyboards used to require special software. Not anymore! With this Copyboard you can configure your settings in the browser, no matter what operating system you have. *Setup required for board network

- [Setup Items]**
- Saving file format
 - Security configuration (Disable to save to USB memory stick or computer)
 - Date setting
 - Resolution, Aspect ratio, etc

N-20 SERIES

• N-20 with optional stand



• N-20 with optional stand and printer



[Main Features]

- Width of the board : 1800mm/72", 1300mm/52"
- Number of Panels : 2 panels
- Hand-scrollable sheet
- Network function
- Color/Monochrome print (when connecting with a printer)
- Save to USB memory stick
- Save to a computer (No software is required)
- Security
 - Disable to save to USB memory stick or Network
 - Disable to save to computer
 - Erase Reminder function
- Color Mode Restriction
- Low Power Consumption
- Quiet operation
- Magnet attachable panel
- Stand height adjustment

The sheet maintenance
In order to keep quality of the sheet, please wipe the sheet with a water-damp cloth regularly.

COPYBOARD
F-20
SERIES

Stylish Model

All the functions of the N-20 with an elegant design. Choose from one of 3 colors to brighten up your meeting room or office. Perfect for reception areas, boardrooms and other places clients and customers frequent.



Modern colors to add a touch of class to your meeting area.

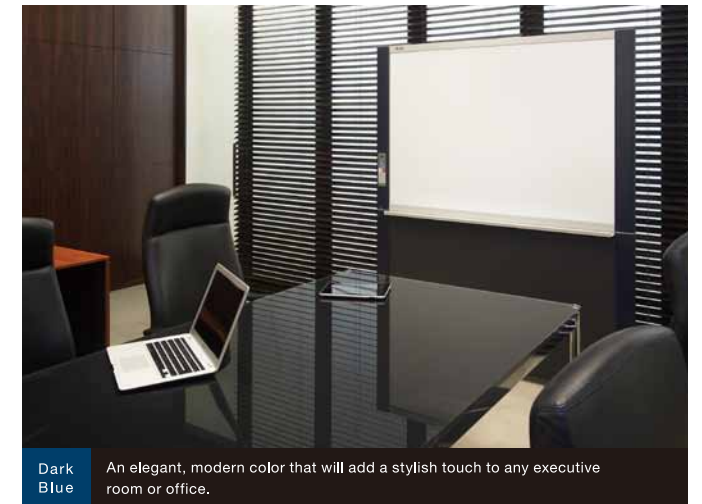

Dark Blue An elegant, modern color that will add a stylish touch to any executive room or office.



White Simple and clean, white has an effortless sophistication that will never look out of place.



Dark Red Turn an open area into a true meeting area. This color goes perfectly with sophisticated furniture and creates a meeting area that people will gravitate toward.

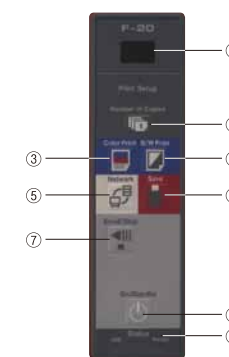

A simpler control panel

The simple-designed control panel allows you to operate the board intuitively.

- ① Display Window
- ② Number of Copies
- ③ Color Print button
- ④ Monochrome Print button
- ⑤ Network button
- ⑥ Save to USB memory stick button
- ⑦ Scroll/Stop button
- ⑧ Power button
- ⑨ Status /Error notification

Configure settings in the browser

Copyboards used to require special software. Not anymore! With this Copyboard you can configure your settings in the browser, no matter what operating system you have.

*Setup required for board network

[Setup Items]

- Saving file format
- Security configuration
(Disable to save to USB memory stick or computer)
- Date setting
- Resolution, Aspect ratio, etc

F-20 SERIES



[Main Features]

- Width of the board : 1300mm/52"
- Number of Panels : 2 panels
- Hand-scrollable sheet
- Network function
- Save to USB memory stick
- Stylish design / choice of 3 colors
- Color/Monochrome print (when connecting with a printer)
- Save to a computer (No software is required)
- Security
Disable to save to USB memory stick or Network
Disable to save to computer
- Erase Reminder function
- Color Mode Restriction
- Low Power Consumption
- Quiet operation
- Magnet attachable panel

The sheet maintenance
In order to keep quality of the sheet, please wipe the sheet with a water-damp cloth regularly.

CAPTUREBOARD
C-20
SERIES

Captureboard

Use the markers to add comments to the projected image, then save the whole thing as an image file. The perfect way to annotate pictures or presentations. And of course you can use the C-20 as a standard Copyboard too!



STEP 1 Project & write

Project an image onto the board and make annotations.

STEP 2 Combine and save

Using a marker, trace the  marks in the four corners to fix the position of the projected image. Click "Combine" on your computer. The projected image and your annotations will be saved together in a single image file.
*Combining software is only compatible with Windows.

STEP 3 Export

Send the saved image via email or print it out from the on-board printer.
*Requires the installation of a printer driver.

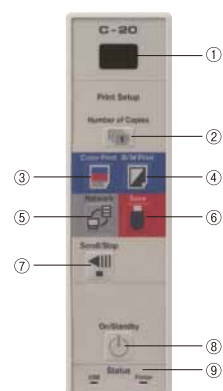
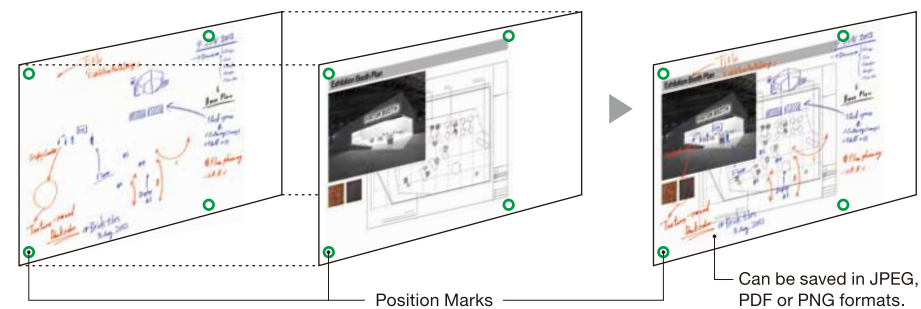

A simpler control panel

The simple-designed control panel allows you to operate the board intuitively.

- ① Display Window
- ② Number of Copies
- ③ Color Print button
- ④ Monochrome Print button
- ⑤ Network button
- ⑥ Save to USB memory stick button
- ⑦ Scroll/Stop button
- ⑧ Power button
- ⑨ Status /Error notification

Easy setup

The board can be easily connected to peripheral devices with standard cables such as USB cables.

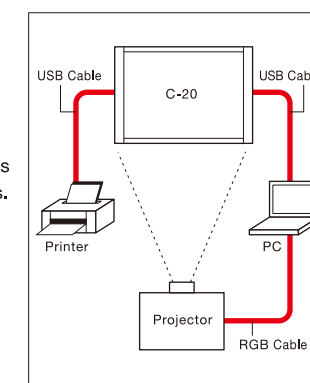

C-20 SERIES

• C-20 with optional stand



• C-20 with optional stand and printer



[Main Features]

- Width of the board : 1800mm/72", 1300mm/52"
- Number of Panels : 2 panels
- Hand-scrollable sheet
- Less light reflection sheet
- Capture function (*Software is compatible only with Windows)
- Network function
- Color/Monochrome print (when connecting with a printer)
- Save to USB memory stick
- Save to computer (No software is required)
- Security
 - Disable to save to USB memory stick or Network
 - Disable to save to computer
 - Erase Reminder function
- Color Mode Restriction
- Low Power Consumption
- Quiet operation
- Magnet attachable panel
- Stand height adjustment

The sheet maintenance
In order to keep quality of the sheet, please wipe the sheet with a water-damp cloth regularly.

CREATIVEPANEL CR-5 SERIES

Compact Model for Individuals and Small Groups

A compact, light and ultra-slim Copyboard perfect to keep by your desk or in small meeting areas. Ideal for brainstorming alone or in small groups.



Simple control panel

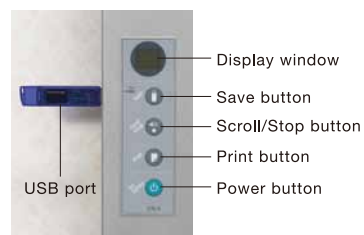

Ultra-slim – just 63mm/2.5"



Print out your notes!



CR-5 SERIES

• CR-5 with optional stand (vertical)



• CR-5 with optional stand and printer (horizontal)



• Wall-mount configuration



The sheet maintenance

In order to keep quality of the sheet, please wipe the sheet with a water-damp cloth regularly.

CASE 1 Working in a team

Often words aren't enough to get your ideas across. Don't let that stop you! With the CR-5 you can create a visual representation of your ideas. When you're done, make a print and use it as a reference. This saves your teammates from taking notes, allowing them to give their full attention to the meeting.



CASE 2 Working with your manager

When you're just talking, things can be unclear and vital information can be forgotten. By writing out important information on the CR-5, you can share information visually and avoid mistakes. You can also send information directly by email—perfect for multi-department projects.



[Main Features]

- Width of the board : 1000mm/40"
- Stylish and Compact design
- Number of Panels : 2 panels
- Hand-scrollable sheet
- Save to USB memory stick (Color inkjet printer is connectable)
- Save to a computer
- Security
 - Disable to save to USB memory stick
 - Disable to save to computer

COPYBOARD BF-041 SERIES

Black and White Thermal Printer Model

An easy-to-use model with a built-in thermal-paper printer. Connects to your computer with a USB cable.

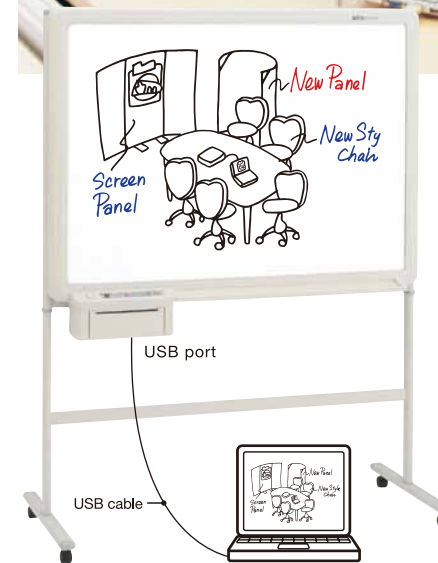

Easy to connect to your computer

With a standard USB port, connecting the Copyboard to your computer is now even easier.

Convenient sliding sheet

As with the N series, you can move the sheet by sliding it with your hand. Move the sheet easily and instantaneously to make more room to write or to see what you wrote on the backside of the sheet.

BF-041 SERIES

[Main Features]

- Width of the board : 1800mm/72", 1300mm/52"
- All in one type
- Number of Panels : 2 panels
- Hand-scrollable sheet
- Built-in thermal printer
- Save to computer

The sheet maintenance

In order to keep quality of the sheet, please wipe the sheet with a water-damp cloth regularly.

Comes with a TWAIN-compatible driver

Turn what you've written into an image file and import it to your computer using the included software. Save in PNG, BMP, JPEG or TIFF format.

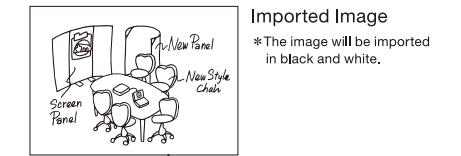

Use graphics tools to edit the image.

Add text to create a report with the image.

Operating environments of the BF-041 software

Supported computer	IBM PC / AT or completely compatible machines
CPU	1.2 GHz or greater
Memory	64 MB or greater (128 MB or greater is recommended)
Free hard disk space	40 MB or greater
Interface	USB 1.1 or USB 2.0
Supported OS	Windows XP (Home Edition) / Professional Edition Service Pack or later) / Windows Vista (32 bit) / Windows 7 (32 / 64 bit)
Display resolution	800 x 600 pixels or higher
Peripheral device	A CD-ROM Drive

Intuitive control panel

■ BF-041S

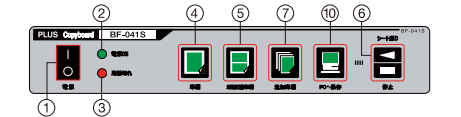



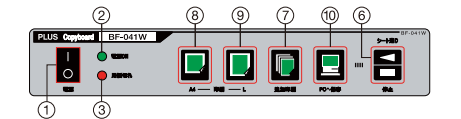





■ BF-041W



- ① Power Switch
- ② Power lamp
- ③ Paper warning lamp
- ④ One-page copy button
- ⑤ Two-in-one page button (BF-041S)
- ⑥ Scroll/Stop button
- ⑦ Repeat button
- ⑧ A4 copy button (BF-041W)
- ⑨ A4-L copy button (BF-041W)
- ⑩ PC save button

Lineups

Models name		N-204 / N-20 series			F-20 series	C-20 series		CR-5	BF series		
Series name	N-204S	N-20W	N-20S	F-20S	C-20W	C-20S	CR-5	BF-041W	BF-041S		
Panel size	Standard	Wide	Standard	Standard	Wide	Standard	Compact	Wide	Standard		
Number of panels	4	2	2	2	2	2	2	2	2		
											
Outer Dimensions with stand (Max)	W1480 x D675 x H1947mm*1 W58.3 x D26.6 x H76.7 inches*1	W1980 x D675 x H1947mm*1 W78.0 x D26.6 x H76.7 inches*1	W1980 x D675 x H1947mm*1 W58.3 x D26.6 x H76.7 inches*1	W1480 x D640 x H1843 mm W58.3 x D25.2 x H72.6 inches	W1980 x D675 x H1947mm*1 W78.0 x D26.6 x H76.7 inches*1	W1480 x D675 x H1947 mm*1 W58.3 x D26.6 x H76.7 inches*1	W1143 x D621 x H1700 mm W45 x D24.5 x H67.0 inches	W1970 x D600 x H1885 mm W77.6 x D23.6 x H74.2 inches	W1470 x D600 x H1885 mm W57.9 x D23.6 x H74.2 inches		
Weight with stand (excluding printer)	38.5kg / 84.8 lbs.	38.5kg / 84.8 lbs.	33.5kg / 73.9 lbs.	56.0kg / 123.5 lbs.	38.5kg / 84.8 lbs.	33.5kg / 73.9 lbs.	19.5kg / 43.0 lbs. (excluding pen tray and AC adaptor)	43kg / 94.8 lbs.	37kg / 81.6 lbs.		
Board	Panel size	W1300 x H910 mm W51.2 x H35.8 inches	W1800 x H910 mm W70.9 x H35.8 inches	W1300 x H910 mm W51.2 x H35.8 inches	W1300 x H910 mm W51.2 x H35.8 inches	W1800 x H910 mm W70.9 x H35.8 inches	W1300 x H910 mm W51.2 x H35.8 inches	W1000 x H610 mm W39.4 x H24.0 inches	W1800 x H920 mm W70.9 x H36.2 inches	W1300 x H920 mm W51.2 x H36.2 inches	
	Effective reading size	W1280 x H900 mm W50.4 x H35.4 inches	W1780 x H900 mm W70.1 x H35.4 inches	W1280 x H900 mm W50.4 x H35.4 inches	W1280 x H900 mm W50.4 x H35.4 inches	W1780 x H900 mm W70.1 x H35.4 inches	W1280 x H900 mm W50.4 x H35.4 inches	W990 x H600 mm W39.0 x H23.6 inches	W1740 x H880 mm W68.5 x H34.7 inches	W1240 x H880 mm W48.8 x H34.7 inches	
	Number of panels	4	2	2	2	2	2	2	2	2	
	Grid	50mm / 2.0" squares	50mm / 2.0" squares	50mm / 2.0" squares	50mm / 2.0" squares	-	-	34 mm / 1.3" squares	50mm / 2.0" squares	50mm / 2.0" squares	
	Paging	Endless in bi-direction (horizontal scrolling)	Endless in one direction (horizontal scrolling)	Endless in one direction (horizontal scrolling)	Endless in one direction (horizontal scrolling)	Endless in one direction (horizontal scrolling)	Endless in one direction (horizontal scrolling)	Endless in one direction (horizontal scrolling)	Endless in one direction (horizontal scrolling)	Endless in one direction (horizontal scrolling)	
	Sheet driving method	Motorized / Manual	Motorized / Manual	Motorized / Manual	Motorized / Manual	Motorized / Manual	Motorized / Manual	Motorized / Manual	Motorized / Manual	Motorized / Manual	
	Reading method	CIS (Contact Image Sensor)	CIS (Contact Image Sensor)	CIS (Contact Image Sensor)	CIS (Contact Image Sensor)	CIS (Contact Image Sensor)	CIS (Contact Image Sensor)	CIS (Contact Image Sensor)	CCD optical sensor	CCD optical sensor	
	Reading illumination light source	RGB LED	RGB LED	RGB LED	RGB LED	RGB LED	RGB LED	RGB LED	Fluorescent lamp	Fluorescent lamp	
Reading resolution	Main scanning direction (vertical sheet surface) 1.92 dots / mm (50 dpi or equivalent), Sub scanning direction (horizontal sheet surface) 1.92 dots / mm (50 dpi or equivalent)			Main scanning direction (vertical sheet surface) 1.92 dots / mm (50 dpi or equivalent), Sub scanning direction (horizontal sheet surface) 1.92 dots / mm (50 dpi or equivalent)*	Main scanning direction (vertical sheet surface) 1.92 dots / mm (50 dpi or equivalent), Sub scanning direction (horizontal sheet surface) 1.92 dots / mm (50 dpi or equivalent)		1.92 dots / mm	2.4 dots / mm	2.4 dots / mm		
Reading time	Color: approx. 15 sec Black & White: approx. 15 sec	Color: approx. 21 sec Black & White: approx. 21 sec	Color: approx. 15 sec Black & White: approx. 15 sec	Color: approx. 15 sec Black & White: approx. 15 sec	Color: approx. 21 sec Black & White: approx. 21 sec	Color: approx. 15 sec Black & White: approx. 15 sec	Color: approx. 15 sec Black & White: approx. 15 sec	Horizontal compression copy: approx. 11 sec Equal ratio copy: approx. 15 sec	1-page copy: approx. 11 sec 2-page reduction copy: approx. 22 sec		
Printer*2	Compatible inkjet printers	Epson single / multi function printers HP PCL3e and some PCL3GUI printers	Epson single / multi function printers HP PCL3e and some PCL3GUI printers	Epson single / multi function printers HP PCL3e and some PCL3GUI printers	-	Epson single / multi function printers HP PCL3e and some PCL3GUI printers	Epson single / multi function printers HP PCL3e and some PCL3GUI printers	-	(Thermal printing)	(Thermal printing)	
	Printing size	A4 / Letter-size	A4 / Letter-size	A4 / Letter-size	-	A4 / Letter-size	A4 / Letter-size	-	A4 / Letter-size (horizontal compression) A4-L (equal ratio)	A4 / letter-size (1-page equal ratio) A4 / letter (2-page reduction)	
	Printing paper size	A4 (210 x 297 mm) / Letter-size (8.5 x 11")	A4 (210 x 297 mm) / Letter-size (8.5 x 11")	A4 (210 x 297 mm) / Letter-size (8.5 x 11")	-	A4 (210 x 297 mm) / Letter-size (8.5 x 11")	A4 (210 x 297 mm) / Letter-size (8.5 x 11")	-	A4 (210 x 297 mm) / Letter-size (8.5 x 11") A4-L (210 x 400 mm / 8.5 x 15.7")	A4 (210 x 297 mm) / Letter-size (8.5 x 11")	
	Colors	Color or Black & White	Color or Black & White	Color or Black & White	-	Color or Black & White	Color or Black & White	-	Black & White	Black & White	
	Print density	300 dpi	300 dpi	300 dpi	-	300 dpi	300 dpi	-	-	-	
	Continuous printing	1 to 10 copies	1 to 10 copies	1 to 10 copies	-	1 to 10 copies	1 to 10 copies	-	1 copy	1 copy	
	Interface	USB2.0 Hi-Speed	USB2.0 Hi-Speed	USB2.0 Hi-Speed	-	USB2.0 Hi-Speed	USB2.0 Hi-Speed	-	-	-	
Interface	Board	File format	JPEG / PNG / PDF	JPEG / PNG / PDF	JPEG / PNG / PDF	JPEG / PNG / PDF	JPEG / PNG / PDF	PNG / JPEG	PNG / BMP / JPEG / TIFF (When connecting to a computer)	PNG / BMP / JPEG / TIFF (When connecting to a computer)	
		Screen size	Standard resolution: 1248 x 864 dots High resolution: 2496 x 1728 dots	Standard resolution: 1728 x 864 dots High resolution: 2496 x 1728 dots	Standard resolution: 1248 x 864 dots High resolution: 2496 x 1728 dots	Standard resolution: 1248 x 864 dots High resolution: 2496 x 1728 dots	Standard resolution: 1728 x 864 dots High resolution: 3456 x 1728 dots	Standard resolution: 1248 x 864 dots High resolution: 2496 x 1728 dots	Standard resolution: 1248 x 864 dots High resolution: 2496 x 1728 dots	-	-
	External memory*3	Type	USB flash memory	USB flash memory	USB flash memory	USB flash memory	USB flash memory	USB flash memory	USB flash memory	-	-
		Compatible FAT types	FAT16, 32	FAT16, 32	FAT16, 32	FAT16, 32	FAT16, 32	FAT16, 32	FAT16, 32	-	-
		Interface	USB 2.0 Hi-Speed	USB 2.0 Hi-Speed	USB 2.0 Hi-Speed	USB 2.0 Hi-Speed	USB 2.0 Hi-Speed	USB 2.0 Hi-Speed	Conforming to USB 2.0	-	-
	Network	LAN port	RJ-45 (10Base-T / 100Base-TX)	RJ-45 (10Base-T / 100Base-TX)	RJ-45 (10Base-T / 100Base-TX)	RJ-45 (10Base-T / 100Base-TX)	RJ-45 (10Base-T / 100Base-TX)	RJ-45 (10Base-T / 100Base-TX)	-	-	
	Printing	Printing resolution	300 dpi or equivalent	300 dpi or equivalent	300 dpi or equivalent	-	300 dpi or equivalent	300 dpi or equivalent	-	-	
No. print colors		16 or grayscale	16 or grayscale	16 or grayscale	-	16 or grayscale	16 or grayscale	-	-		
Printer interface	USB 2.0 Hi-Speed	USB 2.0 Hi-Speed	USB 2.0 Hi-Speed	-	USB 2.0 Hi-Speed	USB 2.0 Hi-Speed	-	-	-		
Power supply	AC power adapter	Input: AC 100-240V / 50-60 Hz, Max 0.75A Output: DC 12V, 3.0A			Input: AC 100-240V / 50-60 Hz, Max 0.75A Output: DC 12V, 3.0A	Input: AC 100-240V / 50-60 Hz, Max 0.75A Output: DC 12V, 3.0A		Input: AC 100-240V / 50-60Hz Max 1.5A Output: DC 24V, 2.0A	-	-	
	Power consumption	Standby : 3W, Operation : 12W	Standby : 3W, Operation : 12W	Standby : 3W, Operation : 12W	Standby : 3W, Operation : 12W	Standby : 3W, Operation : 12W	Standby : 3W, Operation : 12W	Standby : 4W, Operation : 11W	Standby : 3W, Operation : 12W		
Operating conditions	Temperature	10-35°C, 50-95 °F	10-35°C, 50-95 °F	10-35°C, 50-95 °F	10-35°C, 50-95 °F	10-35°C, 50-95 °F	10-35°C, 50-95 °F	10-35°C, 50-95 °F	10-35°C, 50-95 °F	10-35°C, 50-95 °F	
	Humidity	30-85% (no condensation)	30-85% (no condensation)	30-85% (no condensation)	30-85% (no condensation)	30-85% (no condensation)	30-85% (no condensation)	30-85% (no condensation)	30-85% (no condensation)	30-85% (no condensation)	
Accessories*4	Dedicated markers (black, red, blue, green), Dedicated eraser, AC power adaptor (with power cord), USB cable (3m length), Quick guide, Assembly and setup manual, Important safety information, Printer table, Wall mount brackets, CD-ROM (User's manual [PDF])			Dedicated markers (black, red, blue, green), Dedicated eraser, AC power adaptor (with power cord), USB cable (3m length), Quick guide, User's manual, Assembly and setup manual, Important safety information, CD-ROM (User's manual [PDF])	Dedicated markers (black, red, blue, green), Dedicated eraser, AC power adaptor (with power cord), USB cable (3m length), Quick guide, User's manual, Assembly and setup manual, Important safety information, Printer table, Wall mount brackets, CD-ROM (C-20 Software (compatible with Windows XP or later)*5, User's manual [PDF])		Dedicated markers (black, red, blue, green), Dedicated eraser, AC power adaptor, USB cable (3m length), User's manual, Quick guide, Assembly and setup manual, Important safety information, Wall mount brackets, CD-ROM (PLUS TOOLBox software, TWAIN driver, User's manual [PDF])	Dedicated markers (black, red, blue), Dedicated eraser, AC power adaptor, USB cable (3m length), User's manual, Assembly and setup manual, Important safety information, Thermal print paper (30m / 98ft), CD-ROM (TWAIN driver, Image Viewer, Setup utility, User's manual [PDF])			
Computer operating environment*6	Operating system	Microsoft Windows XP (Home Edition / Professional Edition Service Pack 2 or later) / Windows Vista (32bit / 64bit) / Windows 7 (32bit / 64bit) Or, Apple Macintosh computer with standard USB port, Mac OS X 10.5 or later*7			Microsoft Windows XP (Home Edition / Professional Edition Service Pack 2 or later) / Windows Vista (32bit / 64bit) / Windows 7 (32bit / 64bit) Or, Apple Macintosh computer with standard USB port, Mac OS X 10.5 or later*7	When using C-20 software: Microsoft Windows XP (Home Edition / Professional Edition Service Pack 3 or later) / Windows Vista (32bit / 64bit) / Windows 7 (32bit / 64bit) When using the Copyboard as a removable disk: Microsoft Windows XP (Home Edition / Professional Edition Service Pack 2 or later) / Windows Vista (32bit / 64bit) / Windows 7 (32bit / 64bit) Or, Apple Macintosh computer with standard USB port, Mac OS X 10.5 or later		Microsoft Windows XP (Home Edition / Professional Edition Service Pack 3 or later) / Windows Vista (32bit) / Windows 7 (32bit / 64bit)	Microsoft Windows XP (Home Edition / Professional Edition Service Pack 3 or later) / Windows Vista (32bit) / Windows 7 (32bit / 64bit)		
	Web browser	Internet Explorer 8.0 or later Safari 5 or later *Enable JavaScript	Internet Explorer 8.0 or later Safari 5 or later *Enable JavaScript	Internet Explorer 8.0 or later Safari 5 or later *Enable JavaScript	Internet Explorer 8.0 or later Safari 5 or later *Enable JavaScript	Internet Explorer 8.0 or later Safari 5 or later *Enable JavaScript	Internet Explorer 8.0 or later Safari 5 or later *Enable JavaScript	-	-	-	
	Compatible computer types	Preinstalled models operating on one of the operating systems above	Preinstalled models operating on one of the operating systems above	Preinstalled models operating on one of the operating systems above	Preinstalled models operating on one of the operating systems above	Preinstalled models operating on one of the operating systems above	Preinstalled models operating on one of the operating systems above	Preinstalled models operating on one of the operating systems above	Preinstalled models operating on one of the operating systems above	Preinstalled models operating on one of the operating systems above	

*1: The height is adjustable to 1747, 1847, 1947mm

*2: A printer is not included. Printer language compatibility does not ensure the printer connectivity. Be sure to ask your local dealers for compatible printer before purchase.

*3: A USB flash memory is not included. Compatible file formats are FAT16 and FAT32.

*4: Accessories differ from the area you purchase.

*5: C-20 Software is compatible only with Windows.

*6: All operations are not guaranteed under the above operating

*7: When connecting a computer to the board as a removable disk.